

D7005

0.1 – 2.7GHz SP5T Antenna Switch

PRELIMINARY DATA SHEET

Version 1.0

Features

- QFN (14-Pin, 2mm×2mm) Package
- Multi-Band Applications (0.1 – 2.7GHz)
- Low insertion loss and high isolation
- GPIO compatible
- High power handling

Typical Applications

- 2G/3G/4G antenna switch
- LTE TDD/FDD receive diversity
- Portable Battery-Powered Equipment

Product Description

The D7005 is a Single Pole, Five-Throw (SP5T) antenna switch; with high linearity performance and low insertion loss. It is suitable for LTE-based handsets, data cards, and other devices, both for receive diversity and higher power antenna switch, such as in multi-mode GSM/EDGE/WCDMA, TD-SCDMA/TDD-LTE, WCDMA/FDD, and LTE transmit or receive applications.

This part is packaged in a compact 2mm x 2mm, 14- Pin, QFN package, with GPIO compatible logic control.

Optimum Process Technology Applied

√GaAs pHEMT

√Si CMOS

Fig.1 Functional Block Diagram

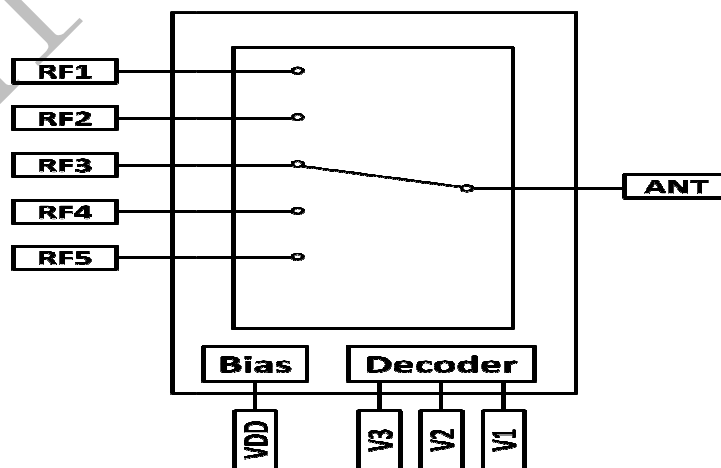

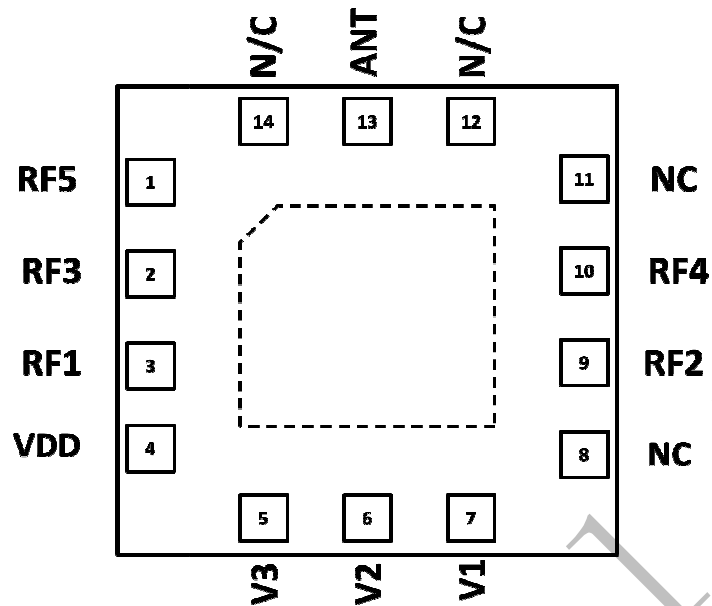

Fig. 2 D7005 Pin Layout (Top View)

Table 1: Pin Description

Pin No	Definition	Description
1~3, 9~10	RF1 ~RF5	Five separately controlled RF paths
13	ANT	Antenna port
5~7	V1~V3	Logic Control "H" : 1.6 ~ 3.0V, Logic Control "L": 0 ~ 0.5V
4	VDD	DC power supply
8, 11, 12,14	NC	Not connected
	Package Base	Ground

Table2: Control Logic Tables

Switched Path	Control Logic		
	V1	V2	V3
RF1 --- ANT	0	0	0
RF2 --- ANT	0	0	1
RF3 ---ANT	0	1	0
RF4 --- ANT	0	1	1
RF5 --- ANT	1	0	0
Power Down (Standby)	1	1	1

Table 3: Absolute Maximum Ratings

PARAMETER	MIN	MAX	UNIT
Supply Voltage VDD	2.5	+5.0	V _{DC}
Control Voltage (V1, V2, V3)	-0.3	+3.0	V
RF Input Power	-	+36	dBm
Operating Case Temperature	-40	+90	°C
Storage Temperature	-55	+150	°C

Cautions ! ESD sensitive device.

Table 4: Electrical Specification

PARAMETER	SPECIFICATION			UNIT	CONDITION
	MIN	TYP	MAX		
					Temp=+25°C, VDD=2.6V, Pin=0dBm, V1/V2/V3 = 0V/1.8V
Supply Voltage VDD	2.5	3.0	5.0	V	
Supply Current IDD		60	90	μA	
Control Voltage V1, V2, V3	Low: 0 ~ 0.5V, High: 1.6 ~ 3.0V				
Control Current		1	5	μA	V1/V2/V3 = 1.8V
Shutdown Current		3		μA	V1=V2=V3=1.8V, VDD=3V
Insertion Loss IL ANT to (RF1~RF5) Ports		0.5 0.8 1.0		dB	0.1 to 1.0 GHz 1.0 to 2.0 GHz 2.0 to 2.7 GHz
Isolation ANT/ All RF Ports		35 30 25		dB	0.1 to 1.0 GHz 1.0 to 2.0 GHz 2.0 to 2.7 GHz
Second Harmonic		-80		dBc	Pin = 26dBm, up to 2.7GHz
Third Harmonic		-80		dBc	Pin = 26dBm, up to 2.7GHz
VSWR		1.1	1.5		Up to 2700 MHz
Impedance		50		Ω	Load impedance presented at RFin pad
Turn-on time			2	μs	Switching between RF ports or turning on

Application Schematic

Device is intended for use in a 50 Ohm system, with a DC-blocking capacitor (any value from 5pF to 15pF) in each RF path.

Power-Up/Down Sequence

In order to avoid damaging the device, if VDD is not supplied at any time, the control voltages must all be set to 0V (or ground).

ON Sequence: First turn ON VDD, then to apply logic control signals, and last RF input.

OFF Sequence: First remove RF input; turn OFF the logic control signals, then turn OFF VDD.

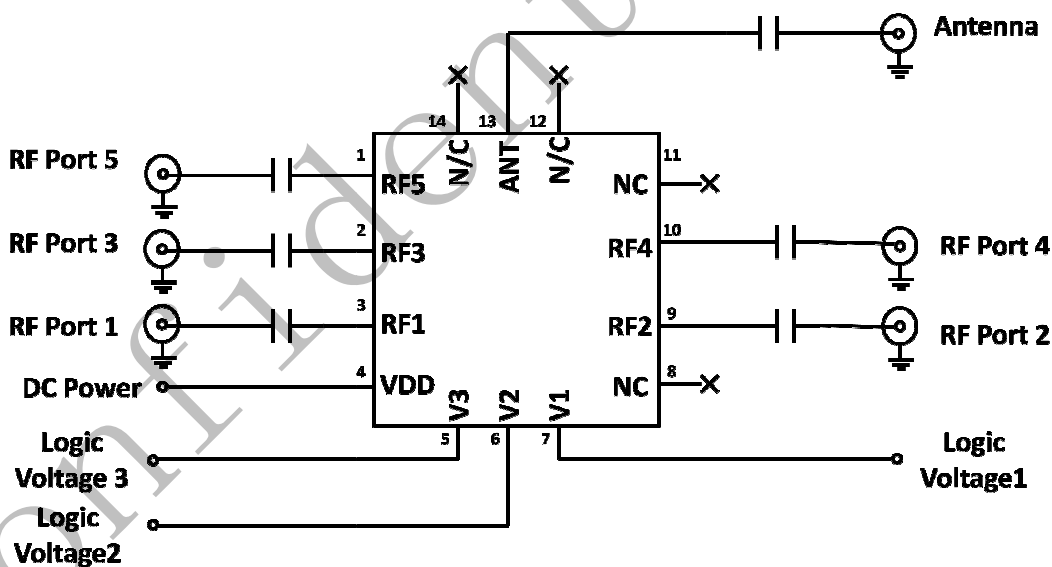

Fig. 3 D7005 Applications Schematic

ORDERING INFORMATION

ORDER NUMBER	TEMPERATURE RANGE	PACKAGE DESCRIPTION	COMPONENT PACKAGING
<u>D7005</u>	-40°C to +90°C	2mm×2mm×0.7mm QFN-14L	Tape and Reel, <u>3000</u> per reel

Disclaimer

Information in this document is for user's reference. These materials are provided by supplier as a service to its customers and may be used for informational purposes only. The supplier assumes no responsibility for errors or omissions in these materials. The supplier may make changes to its products, specifications and product descriptions at any time, without notice. The supplier makes no commitment to update the information and shall have no responsibility for conflicts, incompatibilities, or other difficulties arising from future changes to its products and product descriptions.

All of this information described herein should not be implied or granted for any third party. The supplier does not authorize or warrant any products for use in the life support devices or systems.

Contact Information

For technical questions and additional information about DAC Semiconductor Corporation:

DAC Semiconductor (Kunshan)

Tel: +86-512-5701-7979

Fax: +86-512-5701-7977

DAC Semiconductor (San Jose)

USA Tel: +1-408-435-7930

USA Fax: +1-408-435-7935